

# CONSTANT LATCHING FLUSH BOLT ( FOR METAL DOORS APPLICATION )

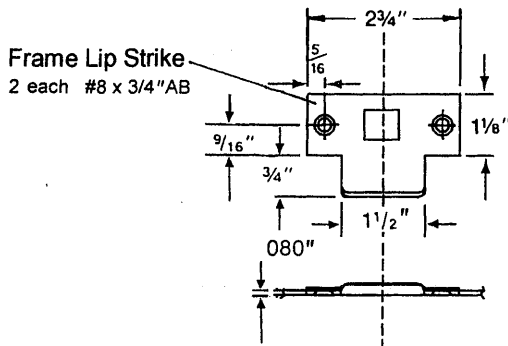

DIMENSIONS SHOWN ON THIS TEMPLATE ARE FOR TOP FLUSH BOLT.

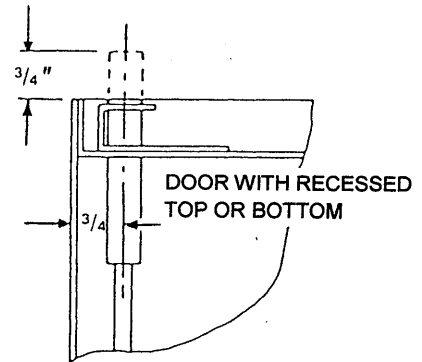
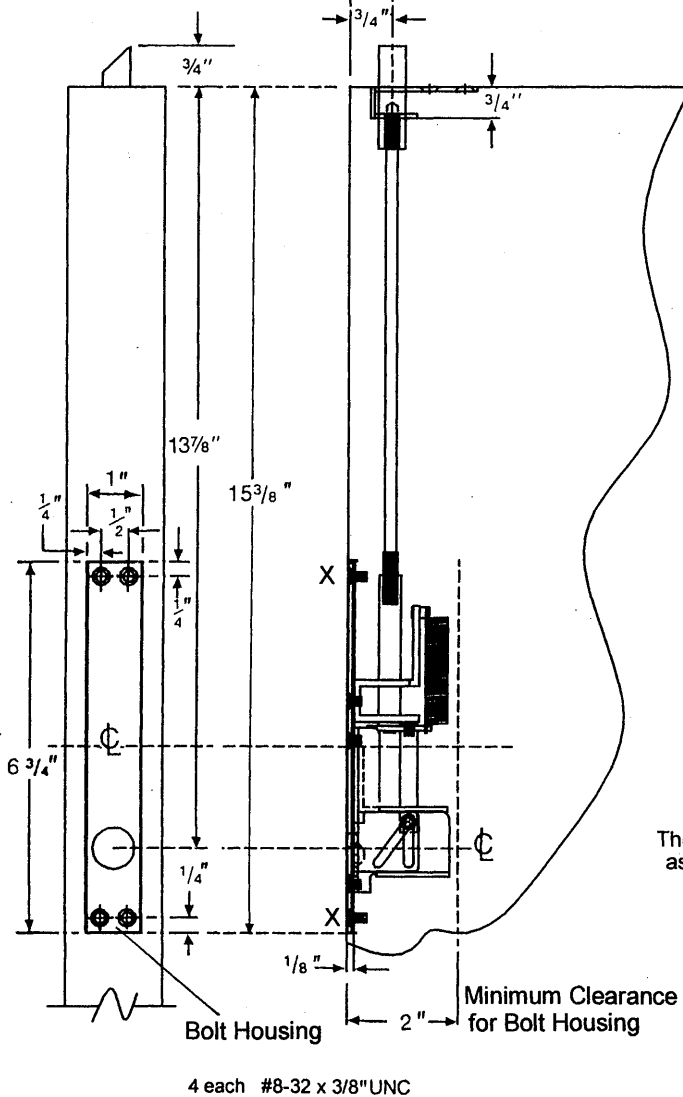
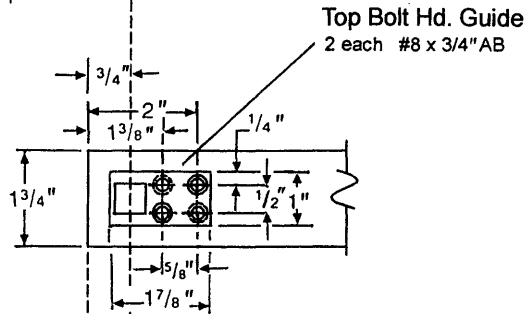

NOTE: WHEN TWO-POINT ENGAGING WITH LATCHING ACTION IS REQUIRED, IT IS RECOMMENDED THAT ONE CONSTANT, SELF-LATCHING FLUSH BOLT BE USED WITH ONE AUTOMATIC FLUSH BOLT. SELF-LATCHING BOLT SHOULD BE INSTALLED AT TOP OF DOOR.

The short screws are seated into the holes of bolt housing as shown mark X, where faces the Bolt Extension Rod.

SCREW DETAILS: #8-32 x 3/8" UNC - flat countersunk head machine screw, total 4 pcs.

#8 x 3/4" AB - undercut flat countersunk head, dual purpose machine/tapping screw, total 4 pcs.