

## VP9042-2 HALF HEIGHT LOCKING PUSH/PULL TEMPLATE/ORDER FORM

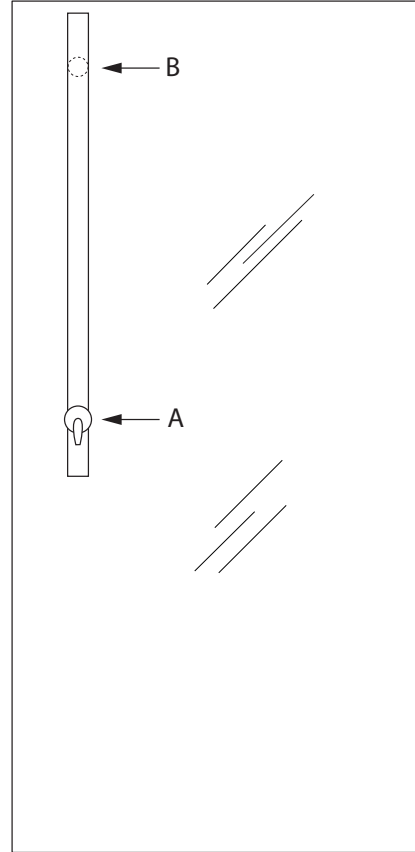
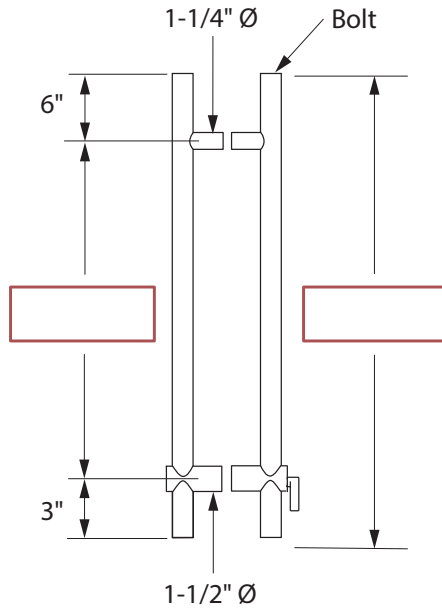

### For All Door Types

- 3/8" to 7/8" thick glass doors
- 1-3/8" to 2-1/2" thick wood or metal doors
- Cylinder must be 34" to 48" above finished floor

### Cylinder Options

- RC - Keyed Rim Cylinder; 5 pin Schlage C Keyway
- SFIC - Best style small format housing; less lock
- LFIC - Schlage large format housing; less lock

Quantity	Finish	Cylinder	Strike	DOOR		
				Thickness	Size	Clearance
<b>EXAMPLE</b> 2 Sets	US32D	RC	901	1-3/4"	83-1/4"	1/8" Top

**Contact:** \_\_\_\_\_ **Customer:** \_\_\_\_\_ **PO#:** \_\_\_\_\_

**Date:** \_\_\_\_\_ **Approved By:** \_\_\_\_\_

**NOTE:** Due to occasional product changes, please ensure your template is current by checking our website at [www.burnsmfg.com](http://www.burnsmfg.com) or call us at 814-833-7428. Burns Mfg is not responsible for obsolete template errors.

**Date: 4/19 - Rev. 3**